

Company Name \_\_\_\_\_

Your Name \_\_\_\_\_

**Open Orbital Weld Head  
TP250 / 400 / 600 / 1000**



1. UTILIZATION OF EQUIPMENT HOURS/PER DAY \_\_\_\_\_
2. QUANTITY OF WELDS PER 8-HOURS DAY \_\_\_\_\_
3. PIPE MATERIAL :

- |                          |                          |                          |                          |
|--------------------------|--------------------------|--------------------------|--------------------------|
| <input type="checkbox"/> | <input type="checkbox"/> | <input type="checkbox"/> | <input type="checkbox"/> |
| SS 316L                  | Titanium                 | Duplex                   | Carbon Steel             |
| <input type="checkbox"/> | <input type="checkbox"/> | <input type="checkbox"/> | _____                    |
| Hastelloy                | Monel                    | Other                    |                          |

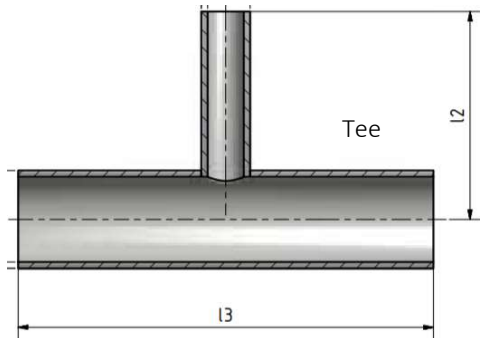
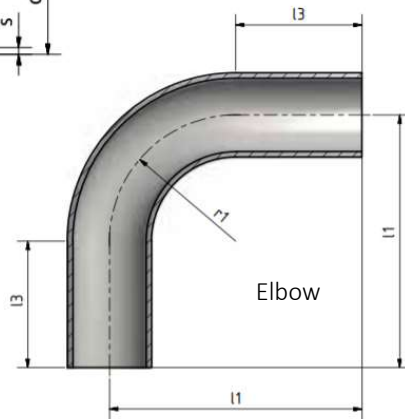
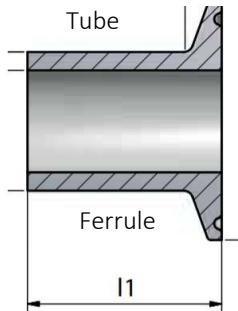
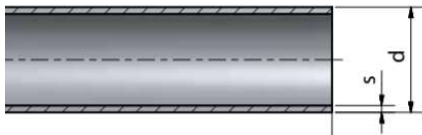

**4. PIPE & FITTING DIMENSION:**

Tube OD, d		WT S, mm	Ferrule l1, mm	Elbow		Tee	
Inch	mm			l3, mm	l1	l3, mm	l2, mm

--	--	--	--	--	--	--	--

--	--	--	--	--	--	--	--

--	--	--	--	--	--	--	--