

Customer Name _____

Date _____

**Enclosed Orbital Weld Head
OW 76S / 115S / 170**



1. UTILIZATION OF EQUIPMENT HOURS/PER DAY _____

2. QUANTITY OF WELDS PER 8-HOURS DAY _____

3. PIPE MATERIAL :



SS 316L



Titanium



Duplex



Carbon Steel



Hastelloy



Monel



Other _____

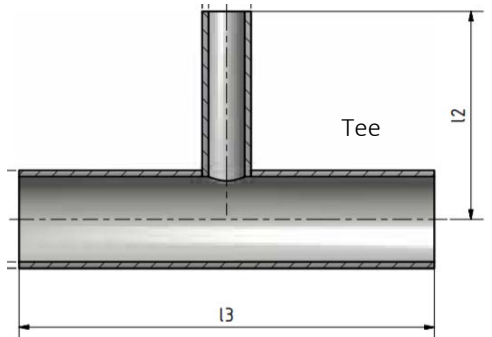
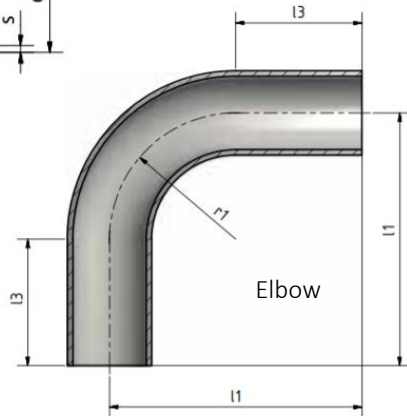
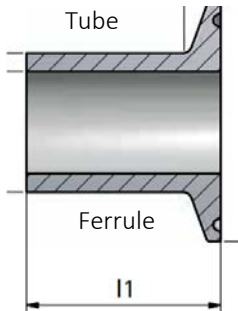
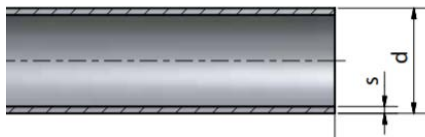

4. PIPE & FITTING DIMENSION:

Tube OD, d		WT S, mm	Ferrule l1, mm	Elbow		Tee	
Inch	mm			l3, mm	l1	l3, mm	l2, mm

--	--	--	--	--	--	--	--

--	--	--	--	--	--	--	--

--	--	--	--	--	--	--	--